

NOTES:

1. ASSEMBLE AND INSPECT PER SOP 620-7918.
2. COLOR DICTATED BY THE SALES ORDER.
 - a. COLOR: -XX COLOR DESIGNATOR AS SPECIFIED IN SOP 620-8222.
 - b. THE -XX CAN RESULT IN ONE COLOR FOR THE METAL SHROUD AND A DIFFERENT COLOR FOR THE METAL FRAME ALSO WITH A -XX LISTED ON THE BOM.
 - c. THE -00XX IS THE COLOR DESIGNATOR FOR UPHOLSTERY.
 - d. THE 5TH DESIGNATOR: "X" WITHIN -XXXXX DEFINES THE HEAD STRAP OR CUSTOM PRODUCTS BRAND. THIS IS SPECIFIED ON SALES ORDERS.
 - e. THE -XXXXX IS CREATED BY COMBINING THE -XX, -00XX AND THE 5TH DESIGNATOR. ALL X'S SHOULD BE DEFINED ON THE SALES ORDER.

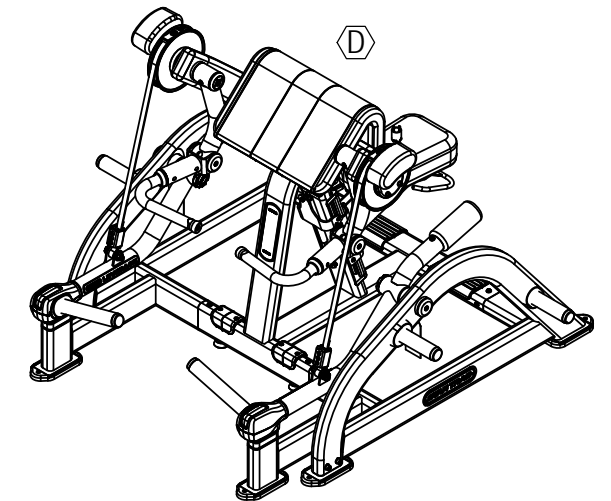
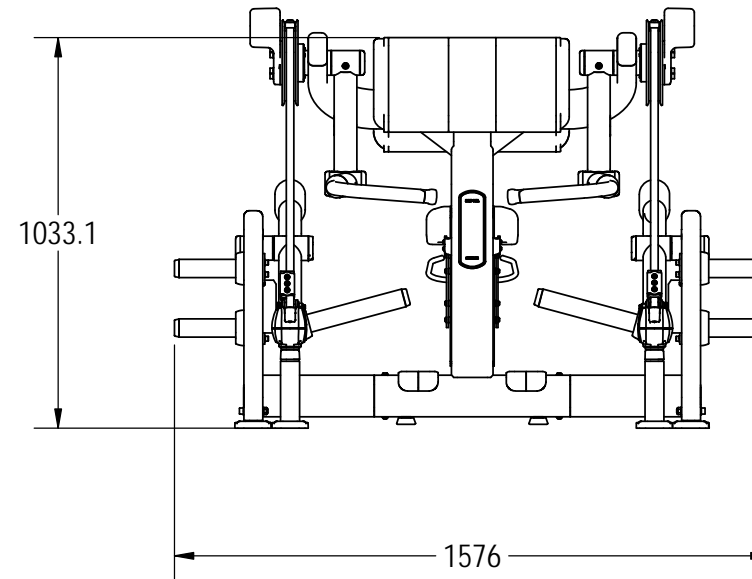
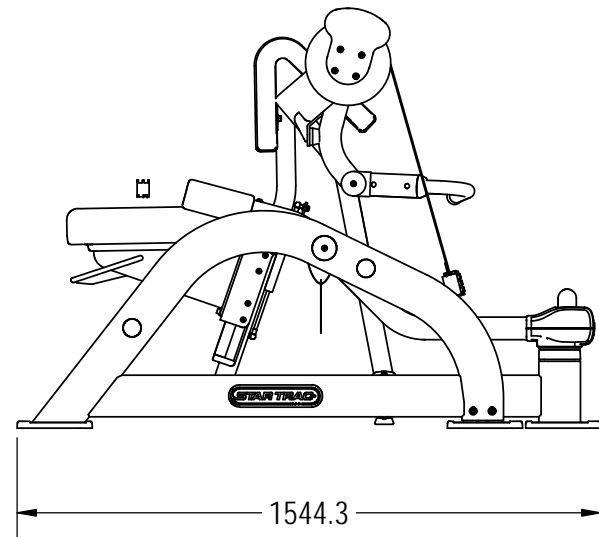
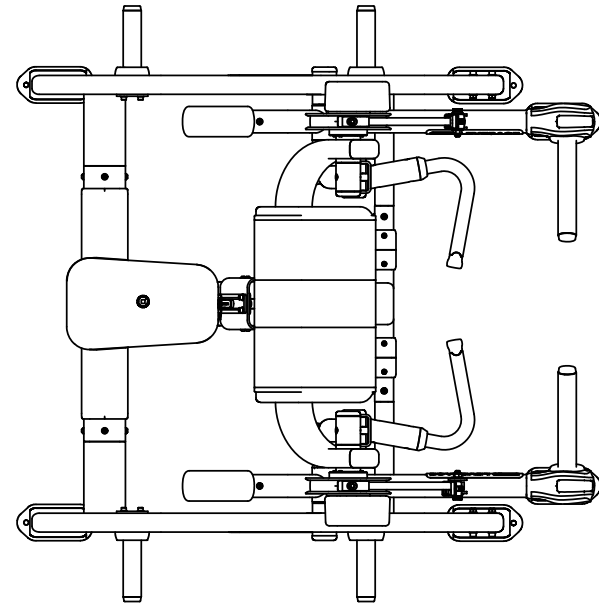

REVISION HISTORY				
REV	DATE	DESCRIPTION	ECO	BY
A	11/1/11	RELEASED @ LAND AMERICA	13736	KEY
B	10/10/13	ROTATE PIVOT POINT, ADJUST CENTER WELDMENT, ADD ONE PIECE WEIGHT HORNS, CHANGE ARMS TO CHROME ADD 731-2640-XX, 731-6038-XX, 731-5607-XX, 731-6037-XX, 731-5603-XX, 731-6047-XX, 731-3850, 731-6008	14423	RLH
C	12/10/2013	ADD PARTS TO MATCH CURRENT BUILD @ LA 731-3872, 731-6075	14480	RLH
D	11/4/2014	UPDATED 731-2959-00XX, 731-2983 TO MATCH PRODUCTION	14765	KY

DOCUMENT STATUS:

NOTICE OF PROPRIETARY INFORMATION
THIS DOCUMENT SHALL NOT BE REPRODUCED NOR SHALL THE INFORMATION CONTAINED HEREIN BE USED BY OR DISCLOSED TO OTHER EXCEPT AS EXPRESSLY AUTHORIZED BY CORE HEALTH & FITNESS, LLC.

CLASS OF WORK	UNLESS OTHERWISE SPECIFIED DIMS ARE IN mm. TOLERANCES FOR MEASURE OF LENGTH ARE:							ANGLES = ±2°		
	0.5 to 3	> 3 to 6	> 6 to 30	> 30 to 120	> 120 to 400	> 400 to 1000	> 1000 to 2000	> 2000		
FINE	±0.05	±0.05	±0.1	±0.15	±0.2	±0.3	±0.5	----		
MEDIUM	±0.1	±0.1	±0.2	±0.3	±0.5	±0.8	±1.2	±2		
COARSE	±0.2	±0.3	±0.5	±0.8	±1.2	±2	±3	±4		
VERY COARSE	----	±0.5	±1	±1.5	±2.5	±4	±6	±8		

MATERIAL SEE BOM	
FINISH N/A	
VENDOR: N/A	P/N: N/A

THIRD ANGLE PROJECTION		
DRAWN	INITIAL	DATE
CHECKED		
APPROVED		
	U.O.M.	MM

CORE HEALTH & FITNESS, LLC 4400 NE 77th Ave., Suite 300 Vancouver, WA 98662		
CORE PART NO	REV	
IP-L5002-XXXXX	D	
TITLE ASSY,LEV, BICEPS CURL		
SCALE: 1:20	SHEET 1 OF 7	SHEET SIZE: B

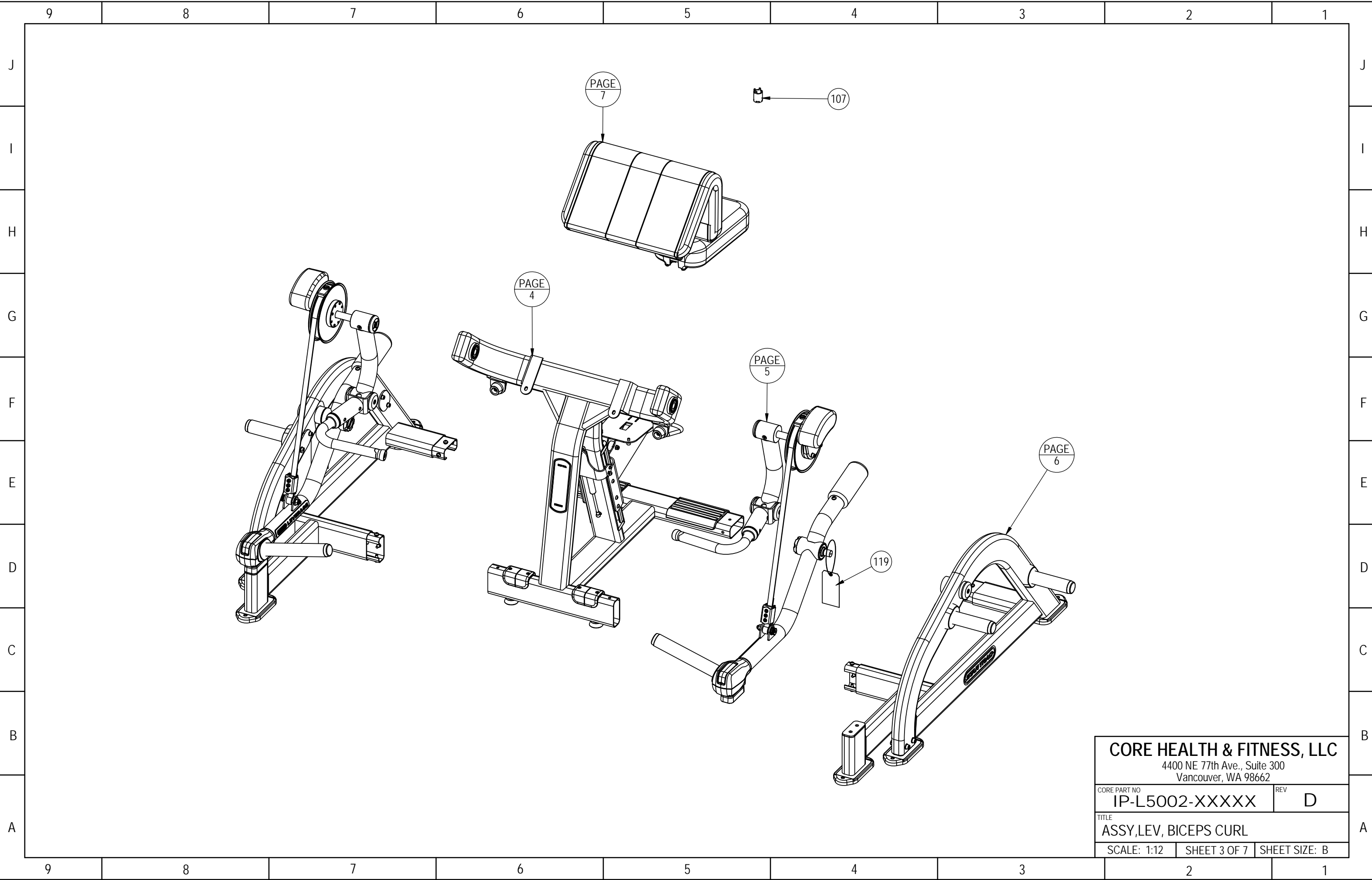

CORE HEALTH & FITNESS, LLC
 4400 NE 77th Ave., Suite 300
 Vancouver, WA 98662

CORE PART NO	REV
IP-L5002-XXXXX	D

TITLE
 ASSY,LEV, BICEPS CURL

SCALE: 1:12	SHEET 3 OF 7	SHEET SIZE: B
-------------	--------------	---------------

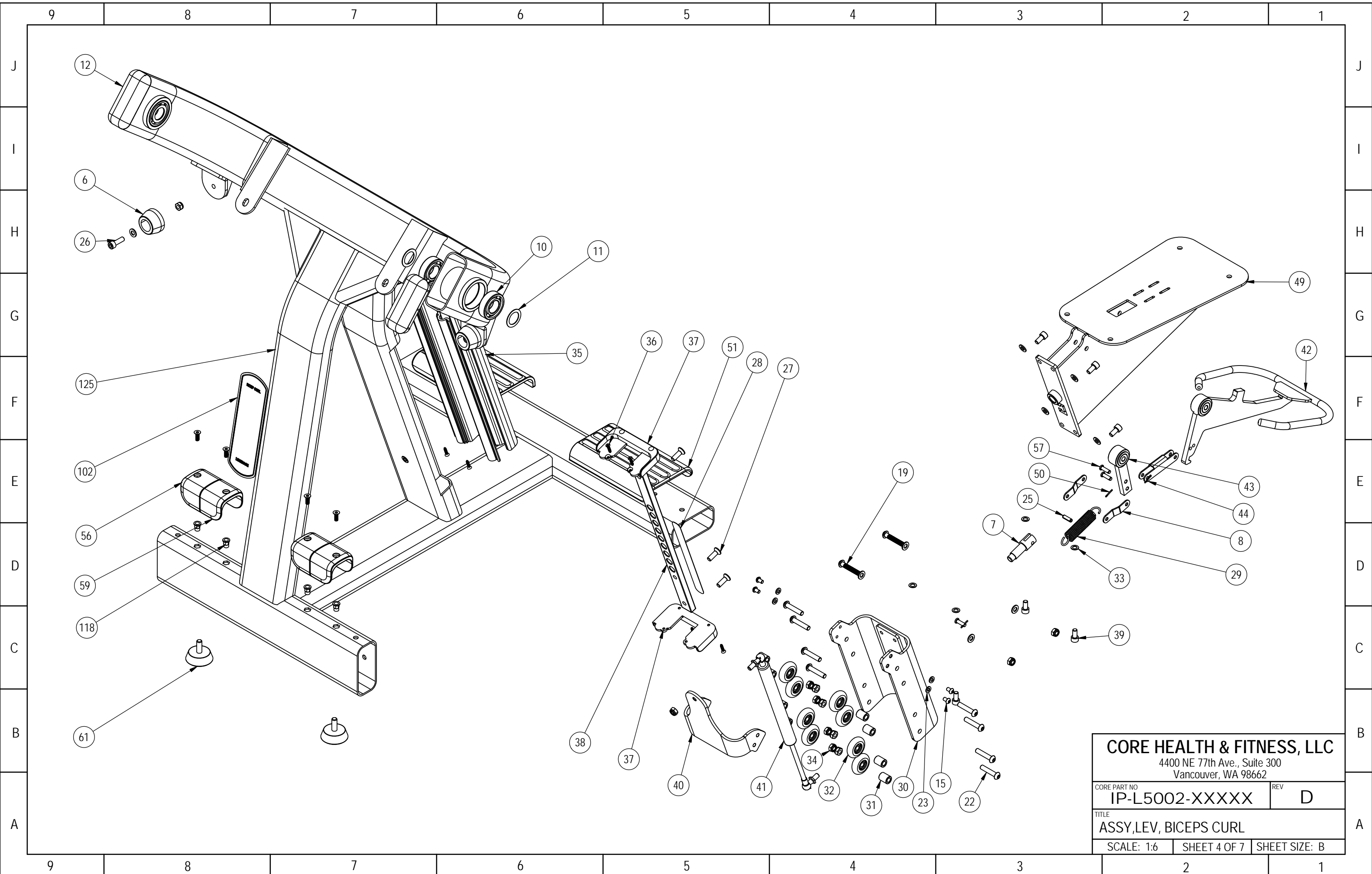

CORE HEALTH & FITNESS, LLC
 4400 NE 77th Ave., Suite 300
 Vancouver, WA 98662

CORE PART NO	REV
IP-L5002-XXXXX	D

TITLE
ASSY,LEV, BICEPS CURL

SCALE: 1:6	SHEET 4 OF 7	SHEET SIZE: B
------------	--------------	---------------

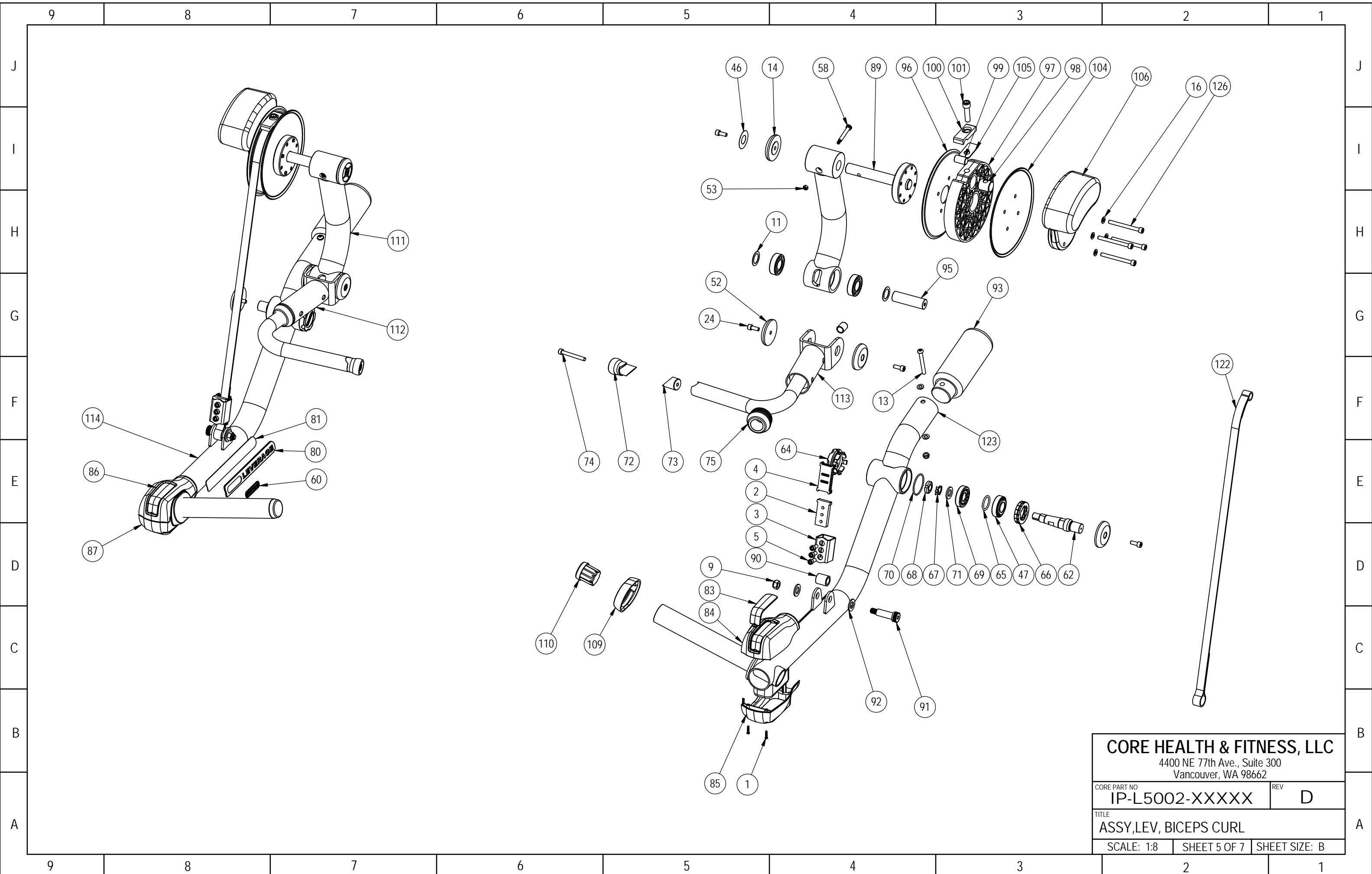

CORE HEALTH & FITNESS, LLC
 4400 NE 77th Ave., Suite 300
 Vancouver, WA 98662

CORE PART NO	REV
IP-L5002-XXXXX	D

TITLE
ASSY,LEV, BICEPS CURL

SCALE: 1:8	SHEET 5 OF 7	SHEET SIZE: B
------------	--------------	---------------

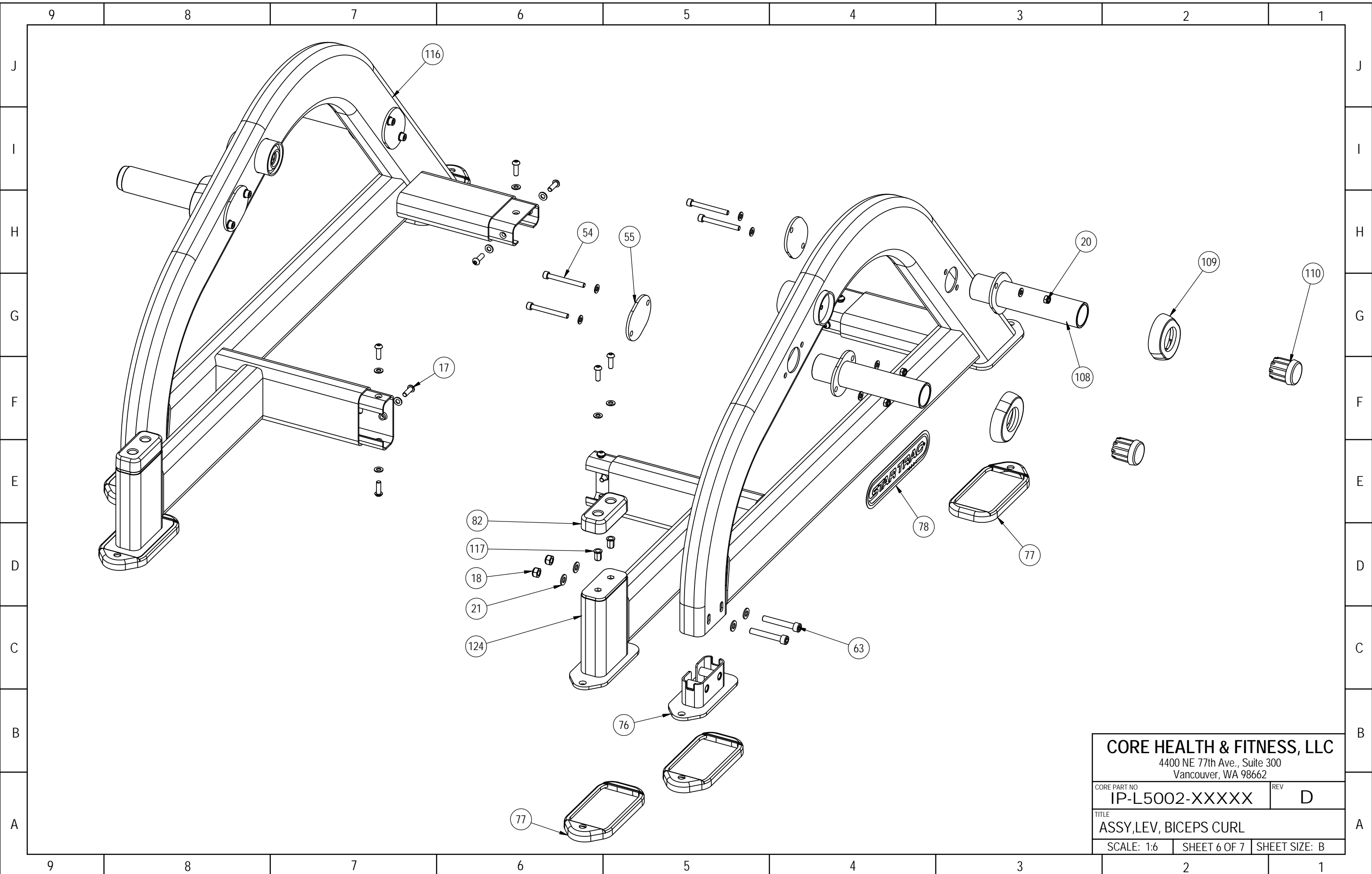

CORE HEALTH & FITNESS, LLC		
4400 NE 77th Ave., Suite 300 Vancouver, WA 98662		
CORE PART NO	REV	
IP-L5002-XXXXX	D	
TITLE		
ASSY,LEV, BICEPS CURL		
SCALE: 1:6	SHEET 6 OF 7	SHEET SIZE: B

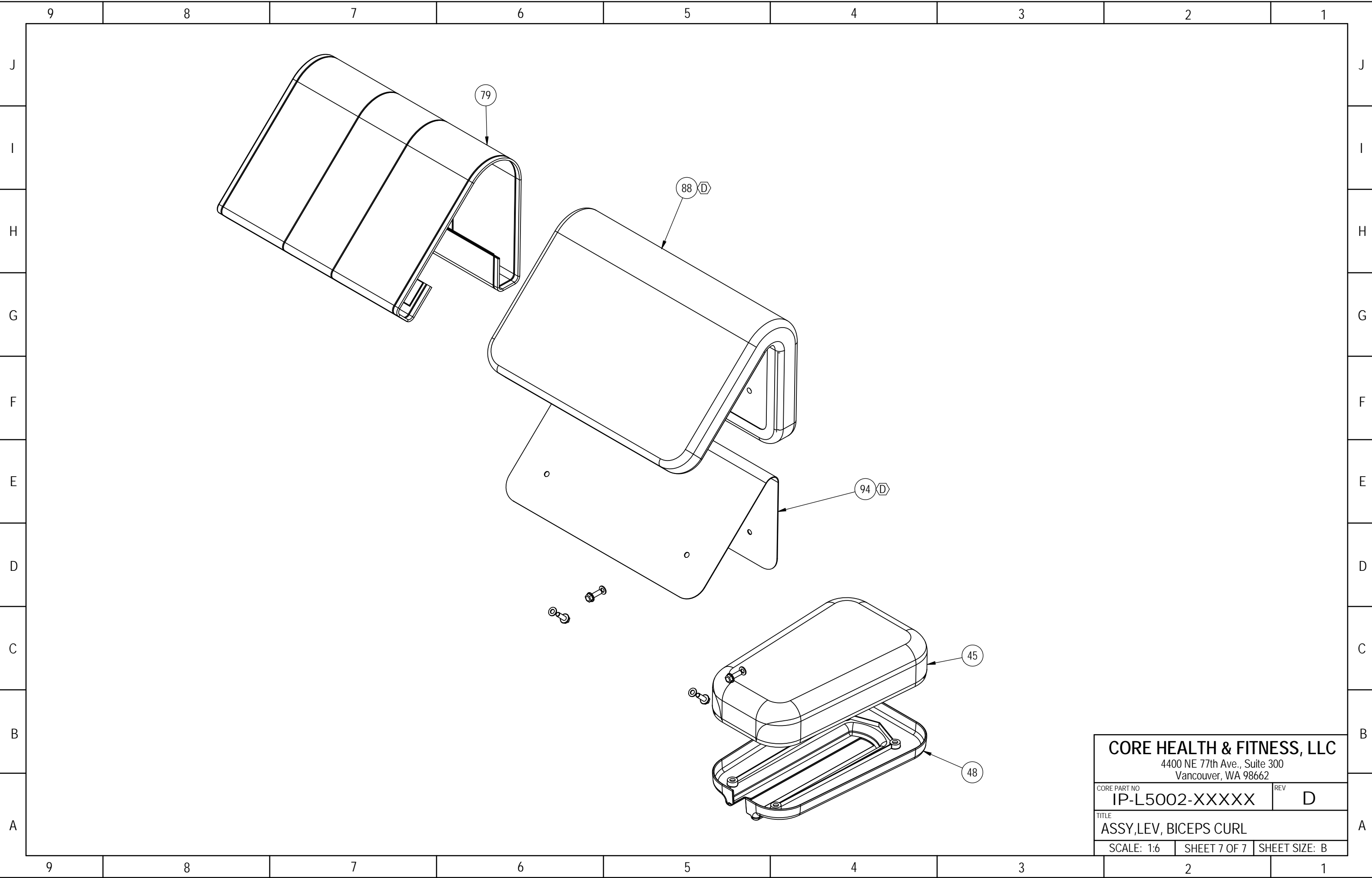

CORE HEALTH & FITNESS, LLC		
4400 NE 77th Ave., Suite 300 Vancouver, WA 98662		
CORE PART NO	IP-L5002-XXXXX	REV D
TITLE ASSY,LEV, BICEPS CURL		
SCALE: 1:6	SHEET 7 OF 7	SHEET SIZE: B